

Congratulations on the purchase of your SAFETY SLEEPER!

Keep these directions handy as you begin to assemble the bed.

It is best to assemble the frame in the same room it will be used, no tools are required for assembly.

All pieces are labeled with numbers and letters.

There are six separate pieces:

- 4 Base (B) pieces: B1, B2, B3, B4 — 4 Support (S) pieces are already connected to the Base: S7, S8, S9, S10
- 2 Top (T) pieces: T5, T6

Build the base of the frame:

1. Lay all 4 pieces labeled B1-B4 on the ground with labels facing up.
2. Move longer support bar in opposite direction from connection points.
3. Connect like parts (B1 to B1, B2 to B2, B3 to B3, B4 to B4) by pushing in button and sliding together until button clicks into place.

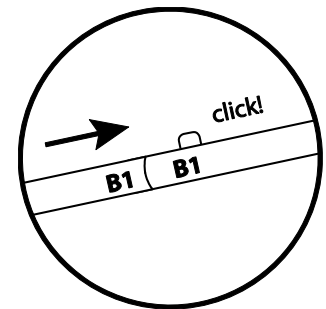

Connect the top pieces of frame:

1. Line up T5 to T5 and T6 to T6 at the same time. Slide them together up to the button at the same time (this prevents them from getting jammed).
2. Push buttons in and slide together until buttons click into place.

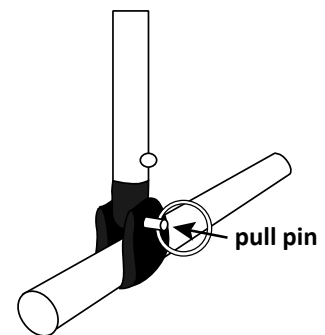

Connect the top piece to the base:

1. Line up T1 to B1 and T2 to B2. Attach with the pull pin—the pull pin is a toggle, it will only slide in one direction.
2. Spread open top bars and bring up support bars to connect at corresponding points, S7 to S10.
3. To release pull pin (the toggle has a spring), push on the spring side to line up toggle and pull out.

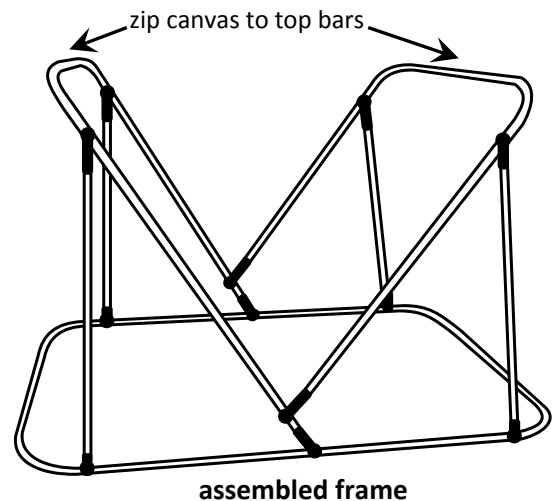

Attach canvas to frame:

1. Lay canvas with zipper side up on the floor, inside base of the frame.
2. Zip to the top front and back horizontal bars of frame.
3. Bed may be placed on top of box spring for added comfort, or remain on the floor.

Insert mattress:

1. Unzip bottom zipper of canvas and slide mattress inside.
2. Zip shut.

Your Safety Sleeper is now ready for use!

To disassemble the Safety Sleeper, simply reverse the order of these directions.